

# ESC-CRZ SERIES

## Z PROFILE SHEET PILES

### HIGH STRENGTH COLD ROLLED Z SHEET PILES IN A WIDE RANGE OF WIDTHS AND THICKNESSES MANUFACTURED IN EUROPE & ASIA

ESC is proud to present its Cold Rolled ESC-CRZ Profile Sheet Piles. The design features interlocks that are located symmetrically on both sides of the neutral axis. The web is continuous, thus the section modulus and shear load transfer are optimised. The profile design has a very competitive strength to weight ratio. Due to a deep profile, the design features a higher Inertia resulting in reduced deflection. This higher inertia together with the option of higher steel grades (430 Mpa) provides the most economic solution that meets the performance requirements. The piles are usually shipped in pairs to accommodate faster installation and better alignment. A wide range of steel grades are available.

#### ORDER OPTIONS

- |                         |   |
|-------------------------|---|
| <b>Steel Grades</b>     | <ul style="list-style-type: none"> <li>✓ Q235B, Q345B, Q345C, Q390B, Q420B</li> <li>✓ S235JR, S275JR, S355JR, S355JO</li> <li>✓ ASTM A572 Gr42, Gr50, Gr60</li> <li>✓ Others available on request</li> </ul>  |
| <b>Length</b>           | <ul style="list-style-type: none"> <li>35.0m maximum</li> <li>Any project specific length can be produced</li> </ul>  |
| <b>Delivery Options</b> | <ul style="list-style-type: none"> <li>✓ Single or Pairs</li> <li>✓ Pairs either loose, welded or crimped</li> <li>✓ Lifting Hole</li> <li>✓ Grip Plate</li> <li>✓ By container (11.8m or less) or Break Bulk</li> <li>✓ Corrosion Protection Coatings</li> </ul> |



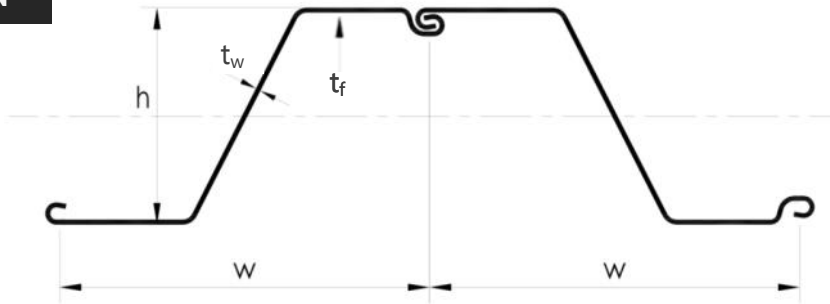

Section	Width (w)	Height (h)	Thickness		Cross Sectional Area cm <sup>2</sup> /m	Weight		Elastic Section Modulus cm <sup>3</sup> /m	Moment of Inertia cm <sup>4</sup> /m	Coating Area (both sides per pile) m <sup>2</sup> /m
	mm	mm	Flange (t <sub>f</sub> ) mm	Web (t <sub>w</sub> ) mm		Per Pile kg/m	Per Wall kg/m <sup>2</sup>			
ESC-CRZ12-700	700	440	6.0	6.0	89.9	49.52	<b>70.6</b>	<b>1,187</b>	26,124	2.11
ESC-CRZ13-670	670	303	9.5	9.5	139.0	73.10	<b>109.1</b>	<b>1,305</b>	19,776	1.98
ESC-CRZ13-770	770	344	8.5	8.5	120.4	72.75	<b>94.5</b>	<b>1,311</b>	22,747	2.20
ESC-CRZ14-670	670	304	10.5	10.5	154.9	81.49	<b>121.6</b>	<b>1,391</b>	21,148	2.00
ESC-CRZ14-650	650	320	8.0	8.0	125.7	64.11	<b>98.6</b>	<b>1,402</b>	22,431	2.06
ESC-CRZ14-770	770	345	10.0	10.0	138.5	83.74	<b>108.8</b>	<b>1,417</b>	24,443	2.15
ESC-CRZ15-750	750	470	7.75	7.75	112.5	66.25	<b>88.34</b>	<b>1,523</b>	35,753	2.19
ESC-CRZ16-700	700	470	7.0	7.0	110.4	60.68	<b>86.7</b>	<b>1,604</b>	37,684	2.22
ESC-CRZ17-700	700	420	8.5	8.5	132.1	72.57	<b>103.7</b>	<b>1,729</b>	36,439	2.19
ESC-CRZ18-630	630	380	9.5	9.5	152.1	75.24	<b>119.4</b>	<b>1,797</b>	34,135	2.04
ESC-CRZ18-700	700	420	9.0	9.0	139.3	76.55	<b>109.4</b>	<b>1,822</b>	38,480	2.19
ESC-CRZ18-630N	630	450	8.0	8.0	132.7	65.63	<b>104.2</b>	<b>1,839</b>	41,388	2.11
ESC-CRZ18-800	800	500	8.5	8.5	127.2	79.90	<b>99.8</b>	<b>1,858</b>	46,474	2.39
ESC-CRZ19-700	700	421	9.5	9.5	146.3	80.37	<b>114.8</b>	<b>1,870</b>	39,419	2.18
ESC-CRZ20-700	700	421	10.0	10.0	153.6	84.41	<b>120.6</b>	<b>1,946</b>	40,954	2.17
ESC-CRZ20-800	800	490	9.5	9.5	141.2	88.70	<b>110.8</b>	<b>2,000</b>	49,026	2.38
ESC-CRZ22-800	800	480	10.0	10.0	149.6	94.00	<b>117.5</b>	<b>2,167</b>	52,000	2.42
ESC-CRZ22-700	700	449	9.0	9.0	149.8	82.33	<b>117.6</b>	<b>2,250</b>	50,509	2.35
ESC-CRZ23-800	800	530	9.5	9.5	147.1	92.40	<b>115.5</b>	<b>2,332</b>	61,811	2.48
ESC-CRZ24-700	700	459	11.2	11.2	177.9	97.75	<b>139.6</b>	<b>2,442</b>	56,036	2.25
ESC-CRZ25-630	630	480	10.5	10.5	180.5	89.29	<b>141.7</b>	<b>2,515</b>	60,360	2.19
ESC-CRZ25-800	800	520	10.5	10.5	163.3	102.60	<b>128.0</b>	<b>2,501</b>	65,060	2.49
ESC-CRZ26-700	700	460	12.2	12.2	194.2	106.70	<b>152.4</b>	<b>2,602</b>	59,838	2.25
ESC-CRZ27-700	700	520	10.5	10.5	176.2	96.84	<b>138.4</b>	<b>2,695</b>	70,166	2.37
ESC-CRZ27-800	800	520	11.5	11.5	176.1	110.60	<b>138.2</b>	<b>2,670</b>	69,419	2.45
ESC-CRZ28-700	700	461	13.2	13.2	212.3	116.66	<b>166.7</b>	<b>2,765</b>	63,741	2.28
ESC-CRZ28-700-12mm	700	499	12.0	12.0	195.4	107.36	<b>153.4</b>	<b>2,801</b>	69,896	2.31
ESC-CRZ28-750	750	560	10.0	10.0	165.4	97.40	<b>129.8</b>	<b>2,813</b>	78,780	2.48
ESC-CRZ29-700	700	540	10.5	10.5	181.5	99.76	<b>142.5</b>	<b>2,959</b>	79,892	2.44
ESC-CRZ30-750	750	550	11.5	11.5	187.8	110.60	<b>147.4</b>	<b>3,006</b>	82,673	2.45
ESC-CRZ32-675	675	476	11.0	11.0	204.4	108.30	<b>160.4</b>	<b>3,279</b>	78,044	2.53
ESC-CRZ32-750	750	560	12.0	12.0	197.2	116.10	<b>154.8</b>	<b>3,202</b>	89,690	2.47
ESC-CRZ33-675	675	485	12.0	12.0	211.7	112.15	<b>166.2</b>	<b>3,292</b>	79,837	2.41
ESC-CRZ35-700	700	540	12.2	12.2	213.9	117.53	<b>167.9</b>	<b>3,567</b>	96,309	2.48
ESC-CRZ36-700	700	540	12.2	12.2	215.0	118.13	<b>168.8</b>	<b>3,609</b>	97,444	2.49
ESC-CRZ37-700	700	499	13.5	13.5	238.2	130.91	<b>187.0</b>	<b>3,728</b>	93,020	2.50
ESC-CRZ38-700	700	560	13.0	13.0	231.3	127.14	<b>181.6</b>	<b>3,868</b>	108,291	2.68
ESC-CRZ40-700	700	580	13.0	13.0	234.9	129.09	<b>184.4</b>	<b>4,015</b>	112,427	2.58
ESC-CRZ44-700	700	580	14.0	14.0	258.3	141.95	<b>202.8</b>	<b>4,443</b>	128,841	2.61
ESC-CRZ46-700N	700	580	14.5	14.5	268.2	147.35	<b>210.5</b>	<b>4,623</b>	134,076	2.62
ESC-CRZ48-700	700	590	15.0	15.0	284.4	156.27	<b>223.2</b>	<b>4,832</b>	142,846	2.68
ESC-CRZ48-585-14.5mm	580	540	14.5	14.5	305.5	139.10	<b>239.8</b>	<b>4,838</b>	130,760	2.47
ESC-CRZ50-580-14.0mm	580	580	14.0	14.0	294.6	134.13	<b>231.3</b>	<b>5,037</b>	140,004	2.47
ESC-CRZ50-580	580	580	16.0	16.0	322.3	146.74	<b>253.0</b>	<b>5,023</b>	145,657	2.37
ESC-CRZ50-700	700	560	16.0	16.0	298.5	164.0	<b>234.3</b>	<b>5,020</b>	140,578	2.61
ESC-CRZ52-700	700	550	16.0	16.0	305.2	167.7	<b>239.6</b>	<b>5,226</b>	143,742	2.70

\*excludes internal section of interlock

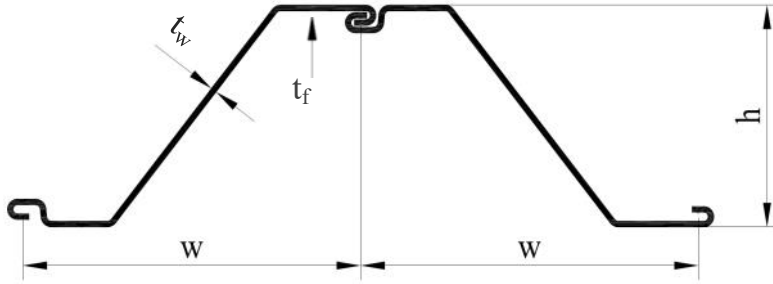

INTERLOCKING CLUTCH



Section	Width	Height	Thickness		Cross Sectional Area	Weight		Elastic Section Modulus	Moment of Inertia	Coating Area (both sides per pile)
	(w)	(h)	Flange ( $t_f$ )	Web ( $t_w$ )		Per Pile	Per Wall			
	mm	mm	mm	mm	cm <sup>2</sup> /m	kg/m	kg/m <sup>2</sup>	cm <sup>3</sup> /m	cm <sup>4</sup> /m	m <sup>2</sup> /m
ESC-M-CRZ12-700	700	314	8.5	8.5	123.5	67.69	96.7	1,180	18,530	1.86
ESC-ML-CRZ12-743	743	407	6.0	6.0	86.0	50.5	68.0	1,150	23,440	1.98
ESC-M-CRZ14A-700	700	316	9.0	9.0	134.5	72.1	103.0	1,410	22,320	1.87
ESC-M-CRZ14B-700	700	354	9.0	9.0	132.8	72.8	104.0	1,410	24,990	1.89
ESC-M-CRZ14C-700	700	315	9.5	9.5	139.0	74.9	107.0	1,360	21,390	1.84
ESC-M-CRZ18-630	630	380	9.5	9.5	153.5	75.93	120.5	1,800	35,970	1.87
ESC-M-CRZ18-700	700	410	9.0	9.0	141.0	77.5	110.7	1,820	37,390	2.02
ESC-ML-CRZ18-720	720	580	6.0	6.0	100.0	56.50	<b>78.47</b>	<b>1,800</b>	52,190	2.23
ESC-M-CRZ19-630	630	380	10.0	10.0	160.0	78.75	125.0	1,880	35,790	1.84
ESC-ML-CRZ19-650	650	576	6.0	6.0	111.5	57.10	<b>87.8</b>	<b>1,960</b>	56,850	2.25
ESC-M-CRZ20-700	700	411	10.0	10.0	150.0	85.96	122.8	2,020	41,410	2.02
ESC-M-CRZ20-743	743	411	10.0	10.0	153.0	89.53	120.5	2,010	41,340	2.11
ESC-M-CRZ22-800	800	475	11.0	11.0	162.5	102.48	<b>128.1</b>	<b>2,180</b>	51,740	2.20
ESC-M-CRZ24-700	700	460	11.0	11.0	177.0	96.6	138.0	2,460	56,560	2.07
ESC-M-CRZ25-630	630	456	10	10.0	176.2	87.13	138.3	2,540	57,910	2.05
ESC-M-CRZ25-750	750	475	11.0	11.0	173.0	102.0	<b>136.0</b>	<b>2,520</b>	59,700	2.19
ESC-M-CRZ27-700	700	456	11.0	11.0	182.0	100.8	144.0	<b>2,710</b>	61,740	2.16
ESC-M-CRZ28-700	700	475	11.0	11.0	185.0	102.2	<b>146.0</b>	<b>2,830</b>	67,110	2.20
ESC-M-CRZ30-700	700	476	12.0	12.0	202.3	111.3	<b>159.0</b>	<b>3,080</b>	73,210	2.20

\*excludes internal section of interlock





## OTHER CONFIGURATIONS

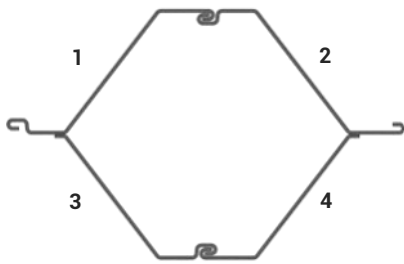

Box King Piles (fabricated out of 2 CRZ Piles & 1 Cold Formed U Pile)

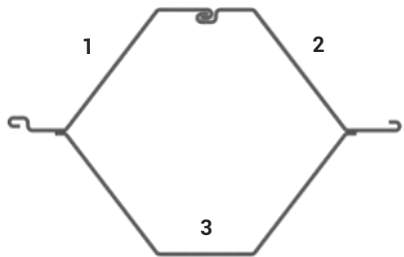

Box King Piles (fabricated out of 2 CRZ Piles & 1 Cold Formed U Pile)



## CORNER PILES

ESC is able to offer 3 options for Corner Pile configurations in the ESC-CRZ Series. Option 1 is frequently used when the installation contractor prefers to create their own corner piles on site depending on the as-driven layout. However this produces wastage on the offcut pile. Option 2 allows welding at the mill or on site and provides the installation contractor with more flexibility on corner pile location. Option 3 provides an option where no welding is required. Option 3 provides increased accuracy at corners that are deviated from the typical 90° corner.

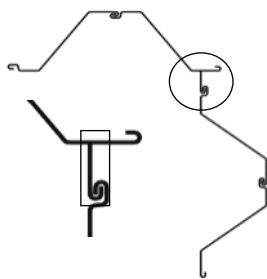

OPTION 1

Cut & weld on section

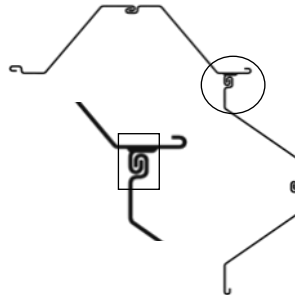

OPTION 2

ESC CR Interlock welded

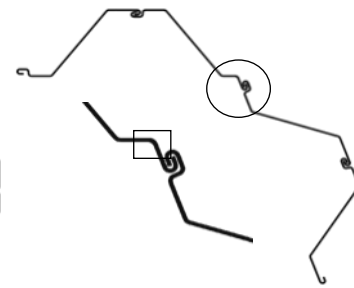

OPTION 3

Cold Form bending of flange

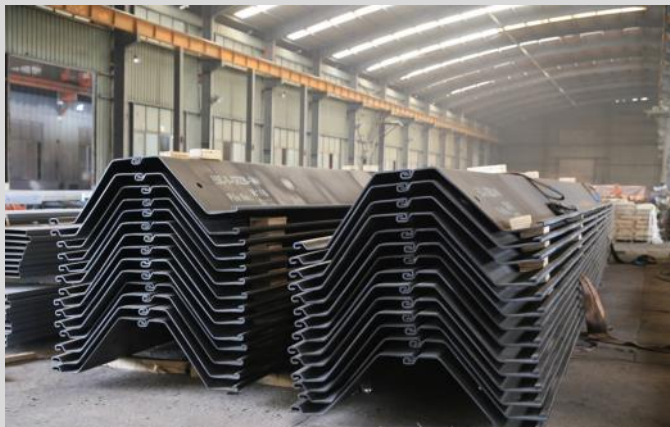

# STEEL GRADES & MANUFACTURING TOLERANCES

## COLD ROLLED & COLD FORMED SHEET PILES

### STEEL GRADES

Classification		Mechanical Properties				Impact Strength (Charpy)	Chemical Composition % (max)				
		Minimum Yield Point MPa		Ultimate Tensile Strength MPa	Elongation % (min)		C	Si	Mn	P	S
		t≤16	16<t≤40		3≤t≤40						
BS EN 10025-2: 2004	S275JR	275	265	410-560	23	27J at 20°C	0.21	-	1.50	0.035	0.035
	S275J2	275	265	410-560	21	27J at -20°C	0.18	-	1.50	0.025	0.025
	S355JR	355	345	470-630	22	27J at 20°C	0.24	0.55	1.60	0.035	0.035
BS EN 102481: 1998	S390GP	390	390	≥ 490	20	-	0.24	0.55	1.60	0.04	0.040
	S430GP	430	430	≥510	19	-	0.24	0.55	1.60	0.04	0.040
GB/T 700:2006	Q235B	235	225	375-500	26	27J at 20°C	0.20	0.35	1.40	0.045	0.045
	Q275B	275	265	410-540	22	27J at 20°C	0.21	0.35	1.50	0.045	0.045
GB/T1591:2008	Q345B	345	335	470-630	20	34J at 20°C	0.20	0.50	1.70	0.035	0.035
	Q390B	390	370	490-650	20	34J at 20°C	0.20	0.50	1.70	0.030	0.030
	Q420B	420	400	540-680	19	34J at 20°C	0.20	0.50	1.70	0.030	0.030
	MDB350	350	350	470-630	21	40J at 20°C	0.20	0.50	1.50	0.025	0.020
ASTMA36-14	A36	250	250	400-550	23	-	0.26	0.40	-	0.040	0.050
ASTM A572-2013a	A572 Gr.42	290	290	≥415	20	-	0.21	0.40	1.35	0.040	0.050
	A572 Gr.50	345	345	≥450	18	-	0.23	0.40	1.30	0.040	0.050
	A572 Gr.60	413	413	≥517	16	-	0.26	0.40	1.35	0.040	0.050
ASTM A690-2013a	A690	345	345	>485	21	-	0.22	0.40	0.60-0.90	0.08-.015	0.040
JIS G3101-2010	SS400	245	235	400-510	17 (5<t<16), 21 (t≤5 or t>16)	-	-	-	-	0.050	0.050
	SS490	285	275	490-610	15 (5<t<16), 19 (t≤5 or t>16)	-	-	-	-	0.050	0.050
	SS540	400	330	≥540	13 (5<t<16), 16 (t≤5 or t>16)	-	0.30	-	1.60	0.040	0.040
JIS A5523-2012	SYW295	295	295	≥490	17	43J at 0°C	0.18	0.55	1.50	0.040	0.040
	SYW390	390	390	≥ 540	15	43J at 0°C	0.18	0.55	1.50	0.040	0.040
MS 2025-1:2006	S235JR	235	225	360-510	26	-	0.17	-	1.40	0.035	0.035
	S275JR	275	265	410-560	23	-	0.21	-	1.50	0.035	0.035
	S355JO	355	345	470-630	22	-	0.20	0.55	1.60	0.030	0.030

### MANUFACTURING TOLERANCES TO BS EN 10249

Component	Tolerance
Mass	± 5%
Length	± 50mm
Height (≤ 200mm)	± 4.0mm
Height (> 200mm & ≤ 300mm)	± 6.0mm
Height (> 300mm & ≤ 400mm)	± 8.0mm
Height (> 400mm)	± 10.0mm
Width of Single Pile	± 2% of width
Width of Double Z or Wide U	± 3% of width
Squareness of Ends	2% of width

Nominal Thickness	Tolerance
5mm	± 0.29mm
6mm	± 0.31mm
8mm	± 0.35mm
9mm	± 0.40mm
10mm	± 0.40mm
12mm	± 0.43mm
13mm	± 0.46mm
15mm	± 0.46mm

### SHEET PILE MARKING

ESC is able to apply adhesive stickers to its products to provide useful information such as destination, order number, project identifier, client name and others. To enable good traceability, material heat number & pile specification is included as standard.



#### Bending B

±0.2% of the length

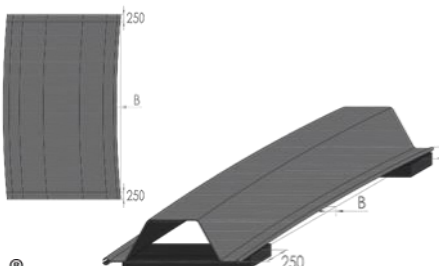

#### Curving C

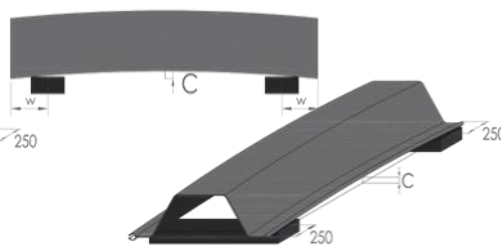

#### Twisting T

±0.2% of the length but no more than 100mm

