

SHEET PILE PROFILE

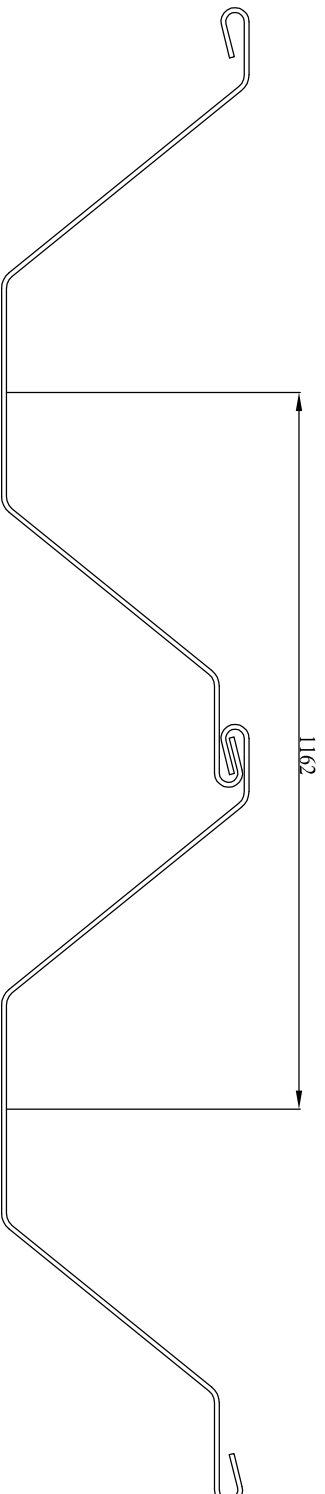

INTERLOCKED PROFILE

COMBINED PILE PROPERTIES								
SERIES	UNIT WIDTH W [in] (mm)	HEIGHT H [in] (mm)	THICKNESS t [in] (mm)	MASS [lb/ft] (kg/m)	MASS [lb/ft ²] (kg/m ²)	TOTAL MODULUS [in ³ /ft] (cm ³ /m)	TOTAL MOMENT OF INERTIA [in ⁴ /ft] (cm ⁴ /m)	Coating Area both side [ft ² /ft] (m ² /m)
ESC-C-CFW13	45.75 (1,162)	15.80 (401)	0.31 (7.75)	73.58 (109.5)	19.34 (94.2)	24.3 (1,308)	192.26 (26,340)	9.19 (2.80)

C			
N			
M			
L			
K			
J			
I			
H			
G			
F			
E			
D			
C			
B			
A	Initial Revision	7.3.11.15	JLY
Issue	Revision	Date	Initial

Notes:
All dimensions in millimetres

ESC Client:

Manufacturer:

ESC Group
Room 209, Dongdu International, No.651
East 2nd Ring Road,
Piaoao District, Shanghai, China
Postal Code: 200092
Pn : +86-21-31263901 Fax : +86-21-31263902
Email : esc@shanghai-esc.com

Project Title:

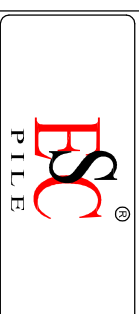

Drawing Title:
**ESC-C-CFW13 SHEET PILE
PROFILE DRAWING**

Stamp:

Signature:

PROFILE DRAWING

Designed JLY	Drawn JLY	Checked CHK	Drawing No.	Rev.
Scale NTS	Date 13.11.2015	Job No. -		A