

DISTRICT COOLING PLANET EXTENSION, UAE

TRENCH SHEETING PROJECT

Project Name	District Cooling Planet Extension
Client	EMPOWER District Cooling
ESC Client	Steel Construction Engineering Company LLC
Location	Business Bay, Dubai, UAE
Product	Trench Sheets
Total Length	1,048 LM
Delivery Date	August 2018 – January 2019

INTRODUCTION

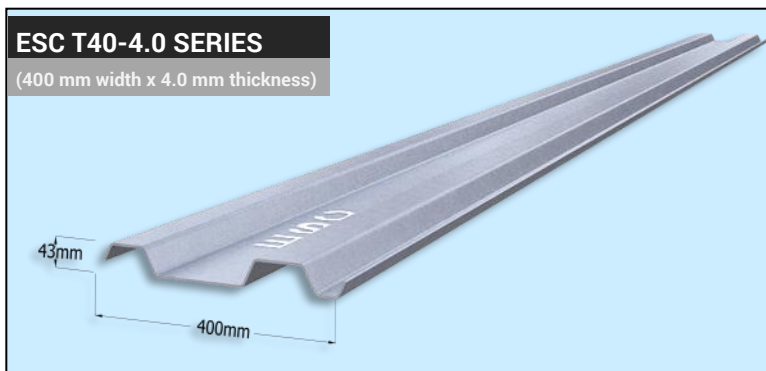

The scope of work involved a trench excavation of approximately 4.0m~6.0m depth. A total of 1,048LM of trench excavation is planned using ESC Trench Sheets.

T40-4.0 Trench Sheets, 6m length with one level bracing was installed to facilitate the necessary excavation for the new chilled water pipe laying works.

ESC SCOPE OF SUPPLY

TRENCH SHEETS

ESC has supplied T40-4.0 Trench Sheets.

These Trench Sheets are 400mm width x 4mm thickness, 6.0m

in length. Total Number of Trench Sheets ordered are 1,400 pcs in phases. Pic 4 illustrates the successful excavation and pipe laying works after the installation of ESC Trench sheets.



ESC-T40-3.5	400.0	42.50	3.5	13.74	34.34	21.98	54.94
ESC-T40-3.7	400.0	42.67	3.7	14.52	36.31	23.14	57.86
ESC-T40-4.0	400.0	42.97	4.0	15.70	39.25	24.85	62.14
ESC-T40-5.0	400.0	43.97	5.0	19.63	49.06	30.41	76.03
ESC-T40-6.0	400.0	44.97	6.0	23.55	58.88	35.77	89.42

ESC T40 Trench Sheet Profile & Mechanical Properties.

PROJECT PHOTOS



TRENCH SHEETS BEING MANUFACTURED



TRENCH SHEETS LOADING FOR DELIVERY



T40-4.0 TRENCH SHEETS



ESC TRENCH SHEETS INSTALLED AMIDST BUSY STREET IN